

Connecting the motors to our CNC controller

- Find the right cables

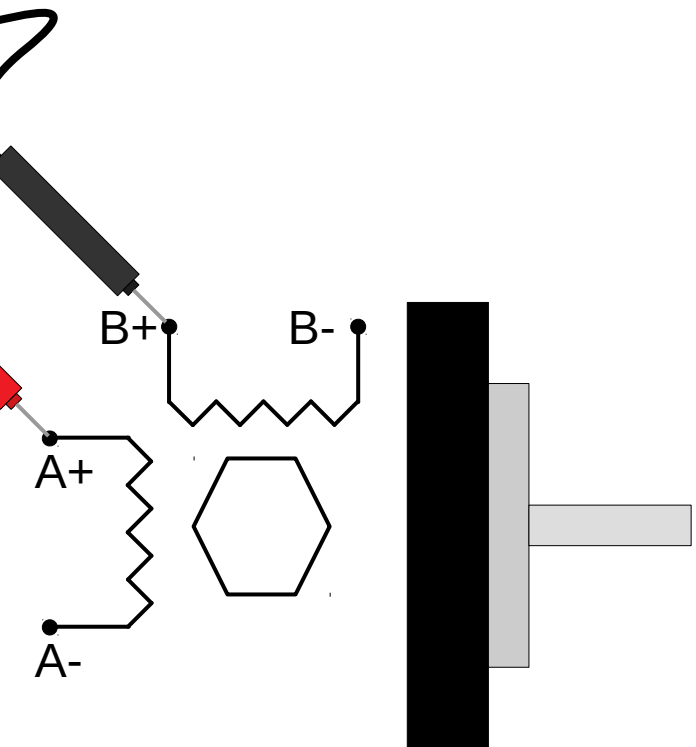
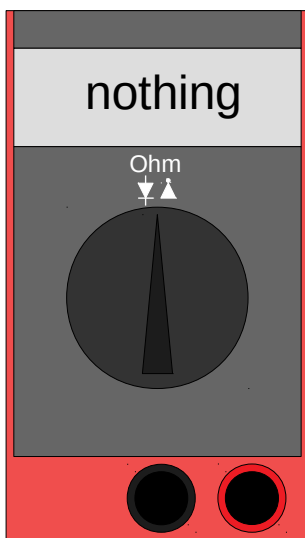
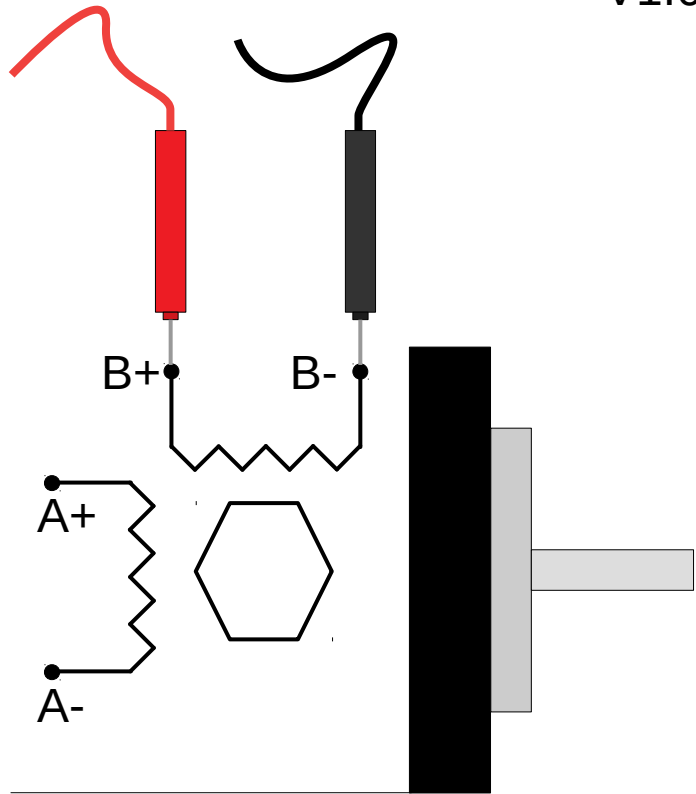

Connecting the motors to our CNC controller

- Change direction of rotation

EN
DINA4
V1.0

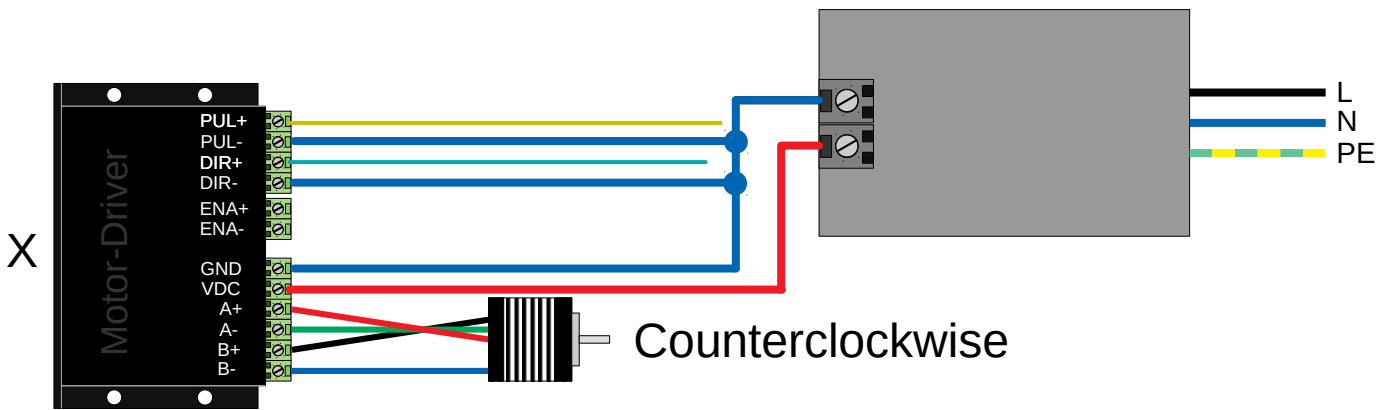
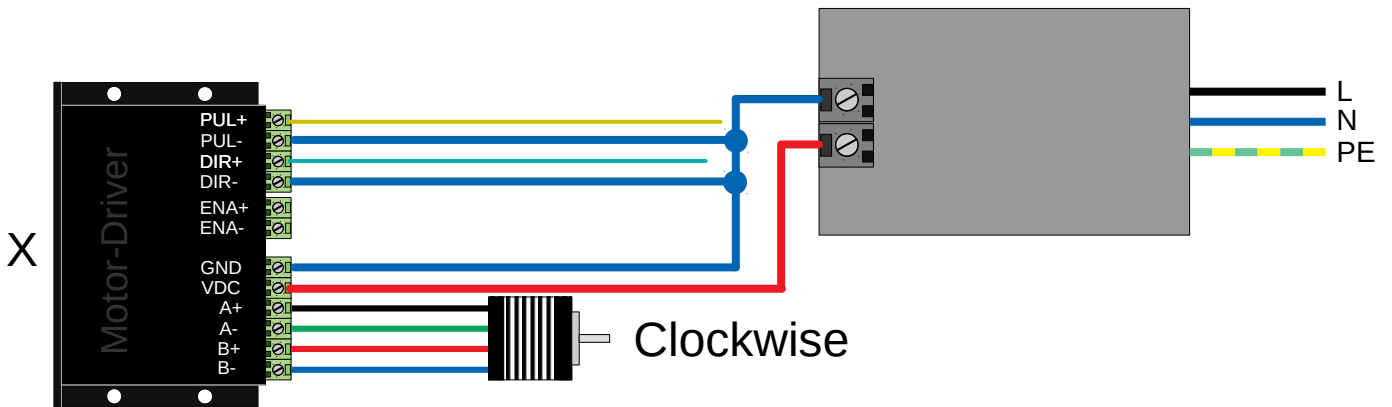

EN
DINA4
V1.0

Connecting the motors to our CNC controller

- One motor per axis

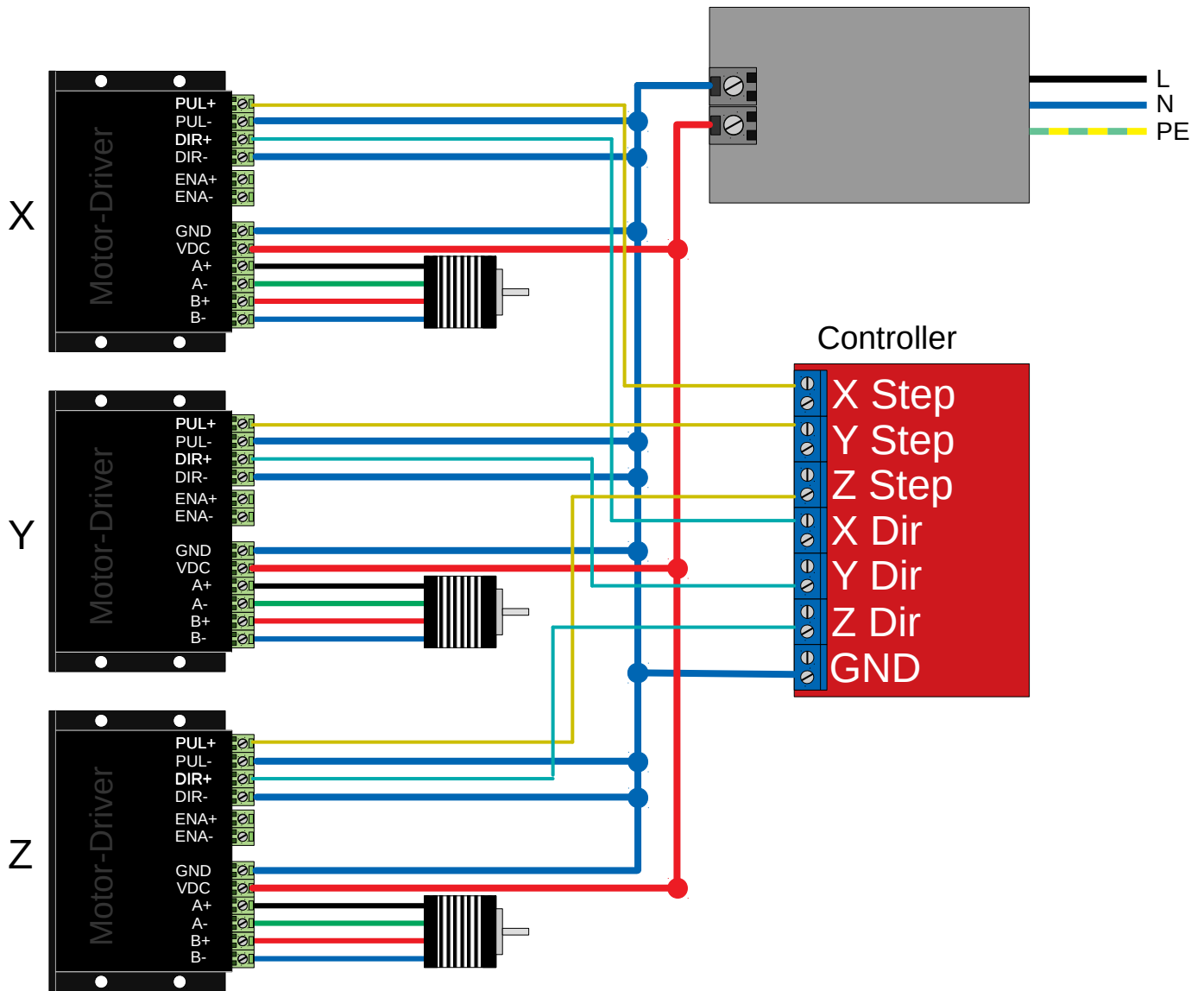

Connecting the motors to our CNC controller

- Two motors on one axis (eg. Z, Z1)

EN
DINA4
V1.0

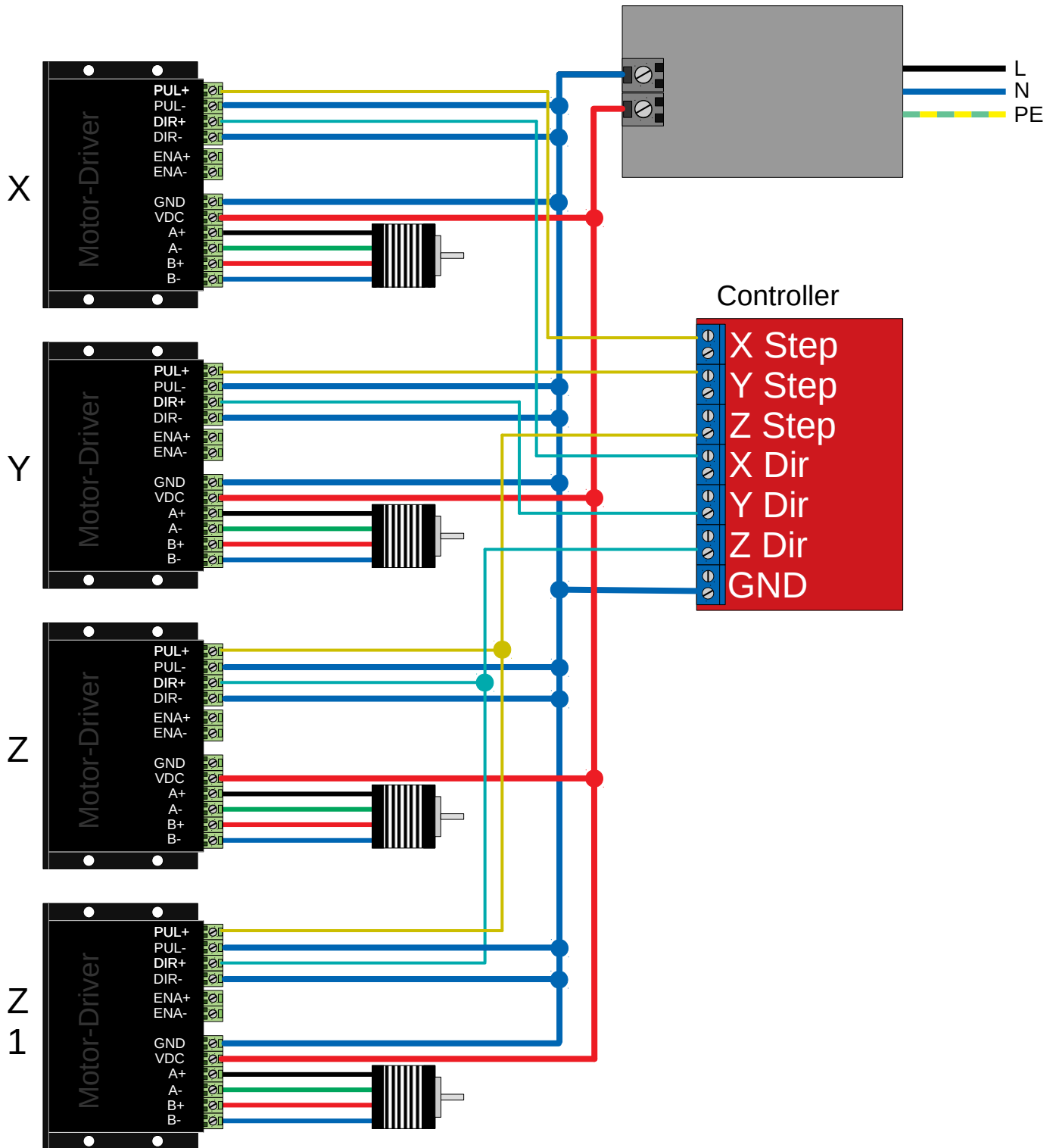

Connecting the motors to our CNC controller

- Two motors on one driver (parallel)

EN
DINA4
V1.0

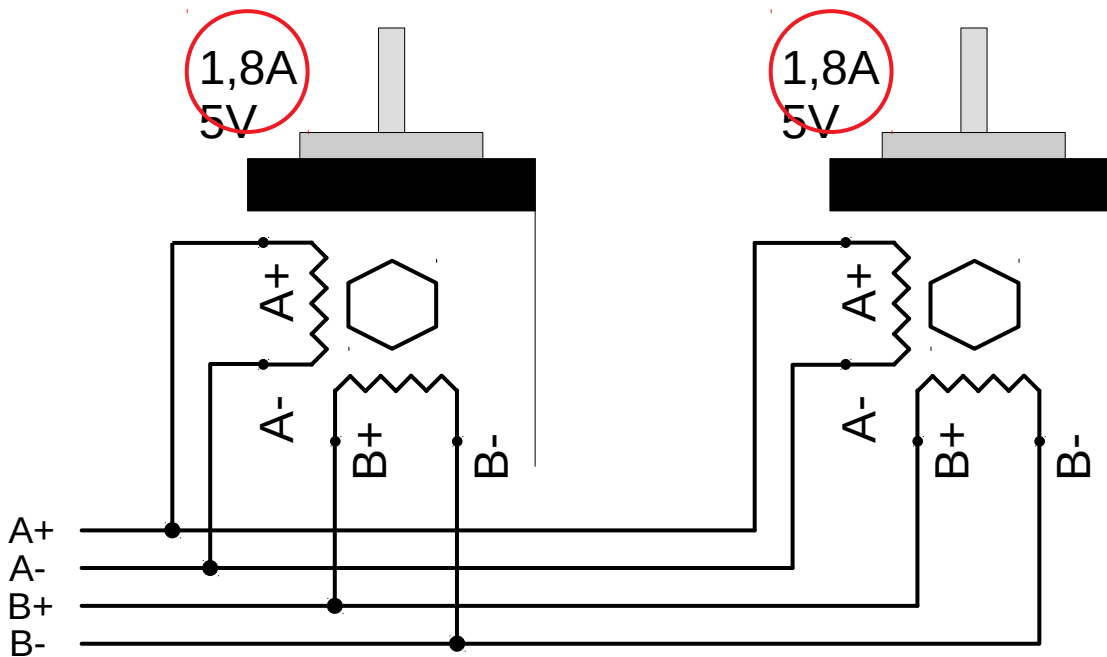
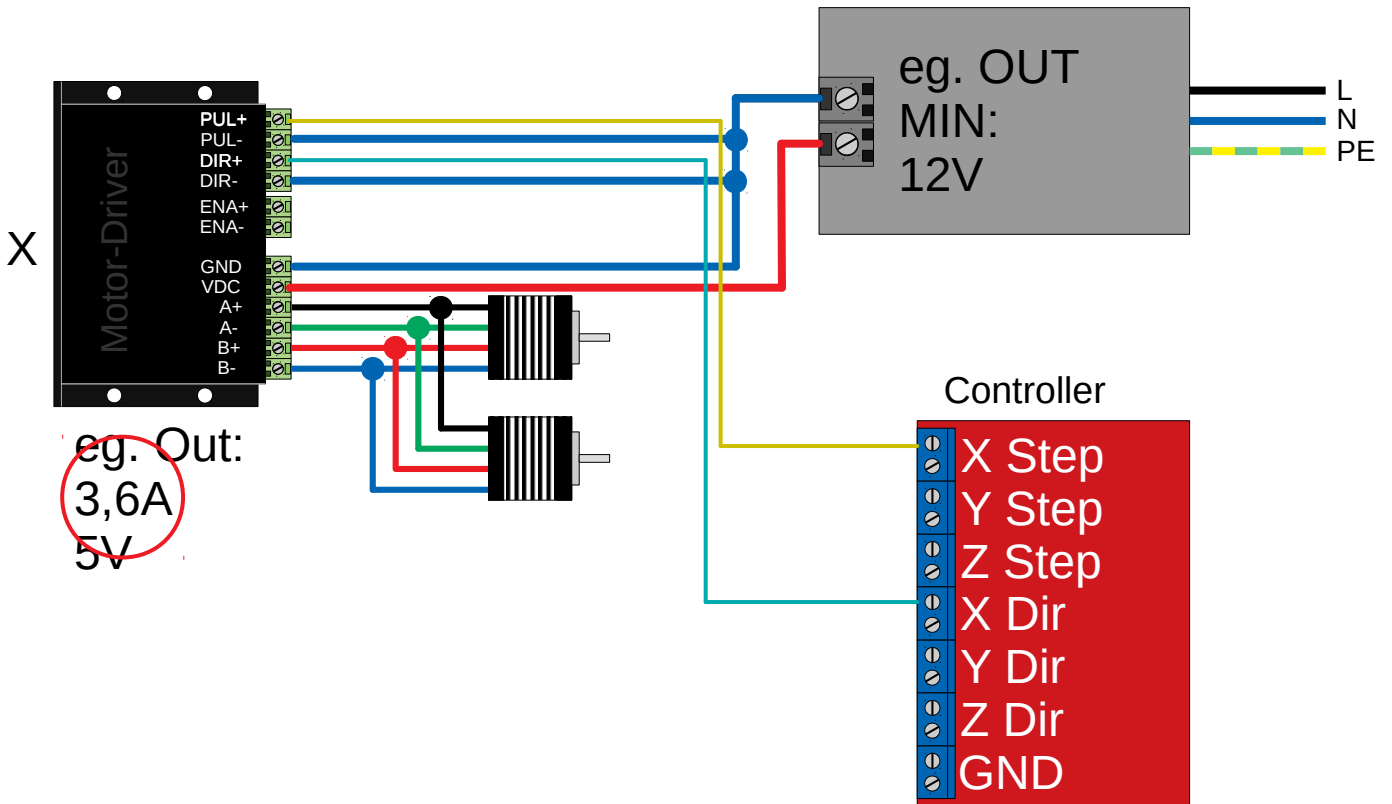

Connecting the motors to our CNC controller

- Two motors on one driver (serial)

EN
DINA4
V1.0

